

SHOCK TEMPERATURE PROTECTOR

Ref.: 2CP1140104



PAP

Assembly Booklet / Paper collection
Livret de montage / Collecte de papier



LDPE

Mini Zip Bag / Plastic collection
Mini sac zip / Collecte de plastique



PAP

Box / Paper collection
Boîte / Collecte de papier



PAP

Carton Separator / Paper collection
Séparateur de cartons / Collecte de papier



C/PAP

Card Header / Paper collection
Carte d'en-tête / Collecte de papier



LDPE

Plastic Bag Cover / Plastic collection
Couverte de sac en plastique / Collecte de plastique



ASSEMBLY SEQUENCE / INSTRUÇÃO DE MONTAGEM

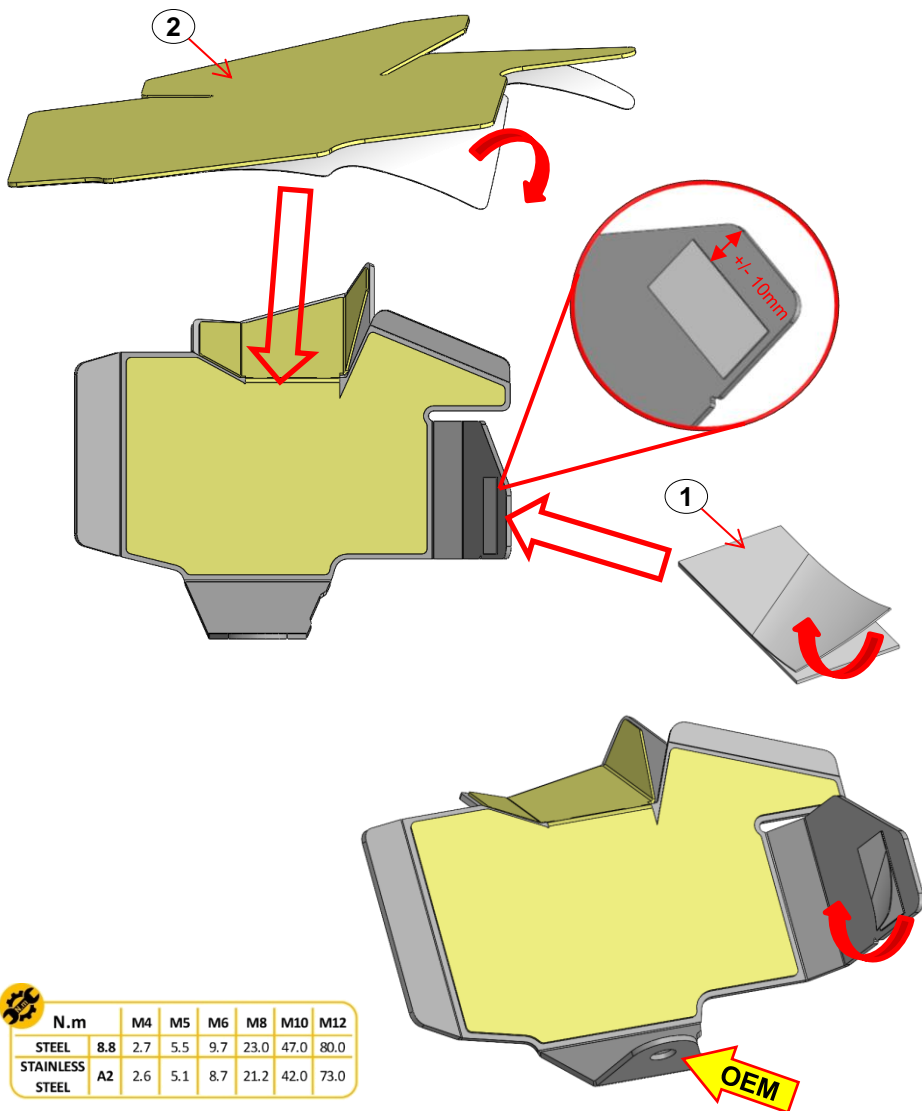

| N.m | M4 | M5 | M6 | M8 | M10 | M12 |
|-----------------|-----|-----|-----|-----|------|------|
| STEEL | 8.8 | 2.7 | 5.5 | 9.7 | 23.0 | 47.0 |
| STAINLESS STEEL | A2 | 2.6 | 5.1 | 8.7 | 21.2 | 42.0 |

| | | | |
|--------------------------|--|--------------------------|---------|
| 2 | Tela Refletora Autocolante / Reflective Screen Sticker | 104 | 1 |
| 1 | Fita Cola Dupla Face / Double Sided Tape | 15mmx30mm | 1 |
| ITEM Nº: | COMPONENTE (COMPONENT): | DESCRIÇÃO (DESCRIPTION): | QUANT.: |
| ACESSÓRIOS (ACCESSORIES) | | | |

SHOCK TEMPERATURE PROTECTOR

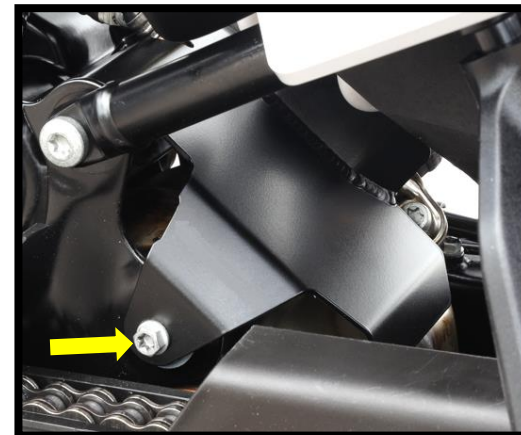

English:

Attention: Follow the installation sequence.

- 1st : Apply items Nº1 (Double Sided Tape – x1) and Nº2 (Reflective Screen Sticker – x1) on protection according to the assembly instruction.
- 2nd : Remove OEM screw.
- 3rd : Assemble protection with OEM screw.
- 4th : Torque the screw to the correct value.

Português:

Atenção – Seguir a sequência de montagem.

- 1º : Aplicar os itens Nº1 (Fita Cola Dupla Face – x1) e Nº2 (Tela Refletora Autocolante – x1) na proteção de acordo com a instrução de montagem.
- 2º : Remover parafuso OEM.
- 3º : Montar proteção com parafuso OEM.
- 4º : Apertar o parafuso com o valor correto de torque.

Français:

Attention: Suivre le séquence d'assemblage.

- 1º Photo: Appliquer les items Nº1 (Ruban Adhésif Double Face – x1) et Nº2 (Autocollant d'Écran Réflecteur – x1) dans la protection conformément aux instructions de montage.
- 2º Photo: Retirer le vis OEM.
- 3º Photo: Monter la protection avec le vis OEM.
- 4º Photo: Torque le vis avec le bonne valeur.